

Show all steps systematically for full credit. Answers with no proper steps will receive 0 credit.  
Total points: 100 (4 points each).

**Solve the problem. If necessary, round to the nearest tenth.**

- 1) A building has a ramp to its front doors to accommodate the handicapped. If the distance from the building to the end of the ramp is 15 feet and the height from the ground to the front doors is 6 feet, how long is the ramp?

**Find the distance between the pair of points. Give your answer in exact form.**

- 3)  $(-2, -3)$  and  $(6, 1)$

**Find the midpoint of the segment with the given endpoints.**

- 4)  $(-2, 6)$  and  $(7, -8)$

**Solve.**

5)  $x^2 + x + 8 = 0$

**Find the missing length(s) in the right triangle. If necessary, round to the nearest tenth.**

2)

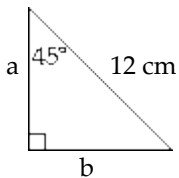

a: \_\_\_\_\_

b: \_\_\_\_\_

Perform the indicated operation and simplify. Write the answer in the form  $a + bi$ .

6)  $3(13 - 9i) - 2(4 - 2i)$

Perform the indicated operation and simplify. Write the answer in the form  $a + bi$ .

10)  $(4 - 2i)^2$

Find the missing length(s) in the right triangle. If necessary, round to the nearest tenth.

7)

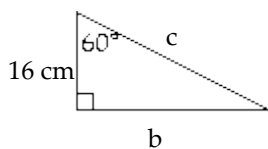

b: \_\_\_\_\_

c: \_\_\_\_\_

Solve.

11)  $(p - 3)^2 = 19$

Perform the indicated operation and simplify. Write the answer in the form  $a + bi$ .

8)  $(8 - 9i)(5 + 9i)$

Perform the indicated operation and simplify. Write the answer in the form  $a + bi$ .

12)  $\frac{5 - 5i}{5 + 2i}$

Find the power of  $i$ .

9) a.  $(i)^{42}$

b.  $i^{357}$

**Solve.**

13)  $p^2 + 5p - 5 = 0$

**Write a quadratic equation having the given numbers as solutions.**

15)  $9 - \sqrt{5}$  and  $9 + \sqrt{5}$

**Use the discriminant to determine the following :**

16)  $7 + 7z^2 = -3z$

Find the discriminant: \_\_\_\_\_

**Solve.**

14)  $4n^2 = -10n - 2$

How many solution? \_\_\_\_\_

What type of solution? \_\_\_\_\_

**Write a quadratic equation having the given numbers as solutions. Write the equation in standard form.**

17)  $-10$  and  $9$

**Solve.**

18)  $8x(x - 5) - 50 = 5x(x - 7)$

20) A ball is thrown downward from a window in a tall building. The distance traveled by the ball in  $t$  seconds is  $s = 16t^2 + 32t$ , where  $s$  is in feet. How long (to the nearest tenth) will it take the ball to fall 206 feet?

**Solve the problem.**

19) Amy travels 450 miles at a certain speed. If the car had gone 15 mph faster, the trip would have taken 1 hour less. Find Amy's speed.

**Solve.**

21)  $(x^2 - 3)^2 - 11(x^2 - 3) + 28 = 0$

22)  $6x^{2/5} + 11x^{1/5} + 4 = 0$

(6 points) Find the vertex, and the axis of symmetry, then graph the function.

24)  $f(x) = (x - 1)^2 - 3$

Vertex: \_\_\_\_\_

Axis of symmetry: \_\_\_\_\_

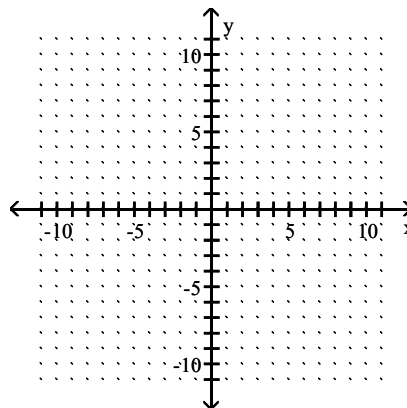

Find the vertex, and the axis of symmetry, then graph the function.

23)  $f(x) = \frac{1}{3}x^2$

vertex: \_\_\_\_\_

Axis of symmetry: \_\_\_\_\_

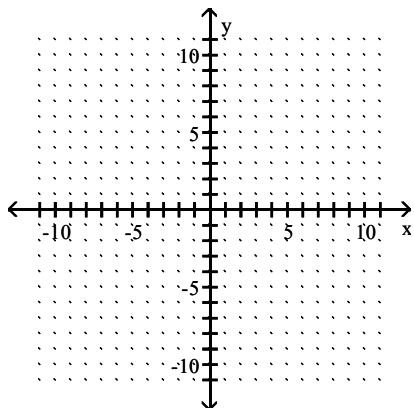

(6 points) Find the vertex and axis of the symmetry, then graph the function.

25)  $f(x) = -(x - 3)^2$

Vertex: \_\_\_\_\_

Axis of symmetry: \_\_\_\_\_

